



BEVERAGE-AIR

Project: _____	AIA#
Item: _____	
Location: _____	SIS#
Approved: _____	

WTRCS72HC CHEF BASE REFRIGERATOR

CHEF BASE REFRIGERATOR

WTRCS72HC Four Drawer Chef Base Hydrocarbon Series

MODEL:
WTRCS72HC



5 Year Parts/Labor Warranty Available
7 Year Compressor Warranty

CABINET CONSTRUCTION

- Stainless steel front, sides, drawers and grille (galvanized back & bottom)
- Interior liner is made of corrosion resistant aluminum
- Top has full marine edge to prevent spills from dripping over sides
- Full electronic control
- Top weight capacity 1500 lbs
- One-piece, snap-in magnetic drawer gasket
- 12-Gauge stainless steel drawer slides with Delrin® rollers rated at 275 lbs
- Lifetime warranty on all drawers and slides
- Heavy duty, fire-proof, reinforced insulated 16 gauge top
- No heat shield required (must adhere to proper clearance per owners manual)
- Accommodates 6" deep full size food service pans (not included)
- Self-closing drawer feature
- Compressor available on left or right, specify at time of unit order
- 3" Casters, 2 with brakes standard

OPTIONS & ACCESSORIES

- 3 Year parts/labor standard, additional 2 year warranty available
- Stainless steel back
- Stainless steel interior
- Additional pan supports
- 6" Adjustable legs, 6" seismic legs
- 6" Casters
- Gasket guards
- Flat top overhang
(up to 6" overhang on each side)
- Remote option*
(refrigerant must be specified at time of order, see note on back on page)

REFRIGERATION SYSTEM

- Uses environmentally friendly, energy efficient R290 refrigerant, and meets all regulatory requirements for CARB, SNAP, DOE & more
- Adaptive defrost
- Non-electric defrost with hot gas condensate evaporation
- Refrigerator capable of maintaining product temperature 36°F to 38°F



Please verify qualifying units by visiting:
www.energystar.gov/cfs

3779 Champion Blvd., Winston-Salem, NC 27105
1-888-845-9800 Fax: 1-336-245-6453
Beverage-Air.com Sales@bevair.com



BEVERAGE-AIR

MODEL	WTRCS72HC
EXTERNAL DIMENSIONAL DATA	
Width Overall	72"
Depth Overall (with handle & bumper)	34 ³ / ₄ "
Height Overall (with casters)	24 ³ / ₈ "
No. of Drawers	4
Depth with Drawers Extended	57 ³ / ₄ "
Drawer Openings	(4) 27 ³ / ₈ " x 6 ¹ / ₂ "
INTERNAL DIMENSIONAL DATA	
NET Capacity (cubic ft.)	14.51
Internal Width Overall (in)	58 ⁷ / ₈ "
Internal Depth Overall (in)	26"
Internal Height Overall (in)	16 ³ / ₈ "
ELECTRICAL DATA	
Full Load Amperes	5.0
REFRIGERATION DATA	
Horsepower	1/3
Capacity (BTU/Hr)	1997
Heat Rejection (BTU/Hr)	2995.5
Charge (lbs/grams)	0.1984/90
WEIGHT DATA	
Gross Weight - Crated	575 lbs
Height - Crated	27"
Width - Crated	78"
Depth - Crated	38"

*NOTE: Remote units are field wired and come with 6" legs. Refrigerant must be specified at time of order.

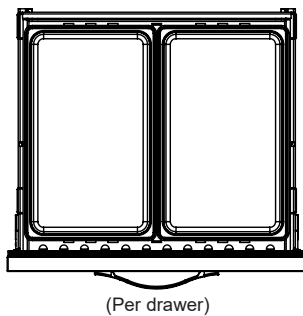

Chef Base Refrigerator Model: WTRCS72HC

Model Views

Required Clearance: Rear 1", Bottom 3 ¹/₁₆"

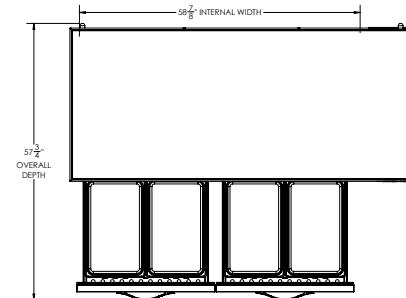

PLAN VIEW

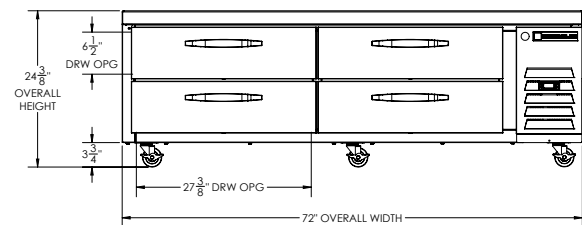

ELEVATION VIEW

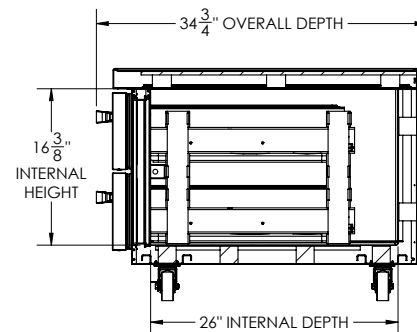

SIDE VIEW

ELECTRICAL CONNECTION



115/60/1
NEMA 5-15P

Unit pre-wired at factory and include 8' long cord and plug set.



3779 Champion Blvd., Winston-Salem, NC 27105 1-888-845-9800 Fax: 1-336-245-6453 Beverage-Air.com Sales@bevaair.com

an Ali Group Company



The Spirit of Excellence